

# MotorGuide® REPAIR PARTS

**Model:**  
**QS410V**

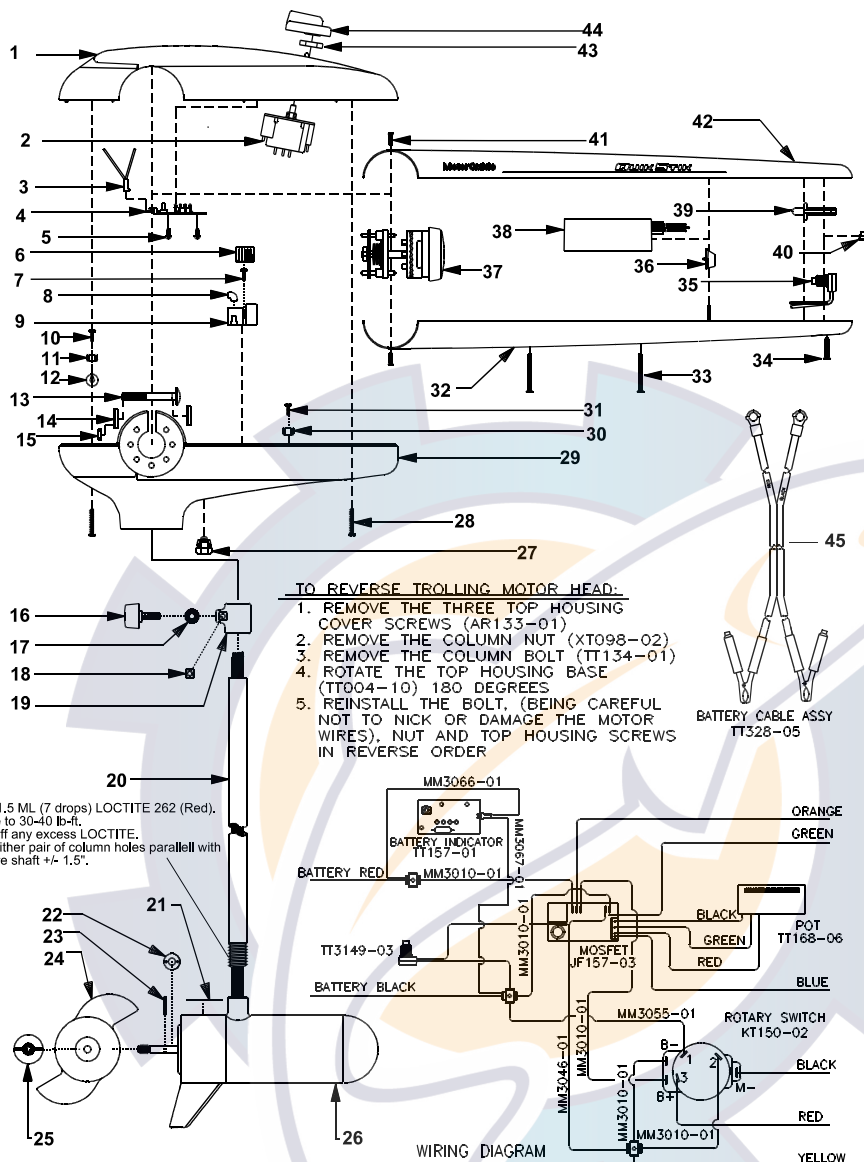

**SPECIFICATIONS:**

Year of Intro	1996
Thrust	45LBS
Volts	12VDC
Amp Draw	0 to 48 amps
Mount	03 Transom
Speeds	Variable

**QUICK REFERENCE PARTS GUIDE:**

Rotary Switch	KT150-02
ON/OFF Switch	TT3149-03
DA Board	JF157-03
MOSFET	JF096-07
Motor Seal Kit	6220
Slide Pot	TT168-06

**PARTS ORDERING & TECH ASSISTANCE**

MotorGuide Consumer Relations  
Phone 918-831-6989  
Fax 800-982-8093

**Send Returned Goods to:**  
MotorGuide  
605 Hwy 12 West  
Starkville, MS 39760

*Returned Goods must be accompanied with a Returned Goods Authorization. Contact MotorGuide Consumer Relations to obtain RGA.*

KEY#	PART#	DESCRIPTION	KEY#	PART#	DESCRIPTION
1	TT053-10	COVER 5 SPD QS GENERIC	26	GF397-01	LOWER UNIT
2	KT150-02	ROTARY SWITCH	27	GR019-01	BATTERY CABLE BUSHING
3	WF329-01	CONNECTOR/JUMPER ASY	28	AR133-01	8 X 1 3/8 SCREW
4	TT157-01	BATTERY LEVEL INDICATOR	29	TT004-10	T/H BASE GENERIC
5	AF141-01	SELF TAPPING SCREW	30	FT160-03	TERMINAL 4 PRONG
6	AP029-01	AMP CONNECTOR	31	GR133-01	310 X 1/2 SCREW
7	AF141-01	SELF TAPPING SCREW	32	TT072-05	LOWER HANDLE QS BLACK
8	AT080-01	INSULATING SLEEVE	33	TT133-03	#6 X 1" SCREW
9	JF157-03	12V DURA AMP BOARD	34	TT133-02	#6 X .75 SCREW
10	GR133-01	310 X 1/2 SCREW	35	TT3149-03	ON/OFF SWITCH ASY
11	FT160-03	TERMINAL (4 PRONG)	36	TT3001-03	ACTUATOR ASY
12	TT098-03	ON SERT PAL NUT	37	TT372-04	HANDLE CLUTCH ASY
13	TT134-01	BOLT	38	TT168-06	POTENTIOMETER
14	TT171-04	CURVED WASHER	39	TT001-04	ACTUATOR ON/OFF
15	XT098-02	NYLON LOCK NUT	40	TT177-02	SWITCH BOOT
16	AR082-02	BAR KNOB DEPTH ADJUST	41	TT133-01	#6 X .437 SCREW
17	AR171-01	COLUMN CLAMP WASHER	42	TT072-12	UPPER HANDLE
18	FR098-01	COLUMN SUPPORT NUT	43	AT098-01	PAL NUT
19	AR051-01	DEPTH ADJUST COLLAR	44	TT082-06	ROTARY KNOB
20	TT049-04	COLUMN 30"	45	TT328-05	BATTERY CABLE ASY
21	FR049-15	COLUMN 42"			
22	ET060-04	LOWER UNIT DECAL			
23	AR175-01	MONOFILAMENT WASHER			
24	BR102-01	PROP PIN			
25	AF124-10	3 BLADE PROP			
	AR099-01	PROP NUT			

PARTS NOT ILLUSTRATED  
ET056-05 DECAL  
MM5604 OWNERS MANUAL

Model:  
**QS410V**

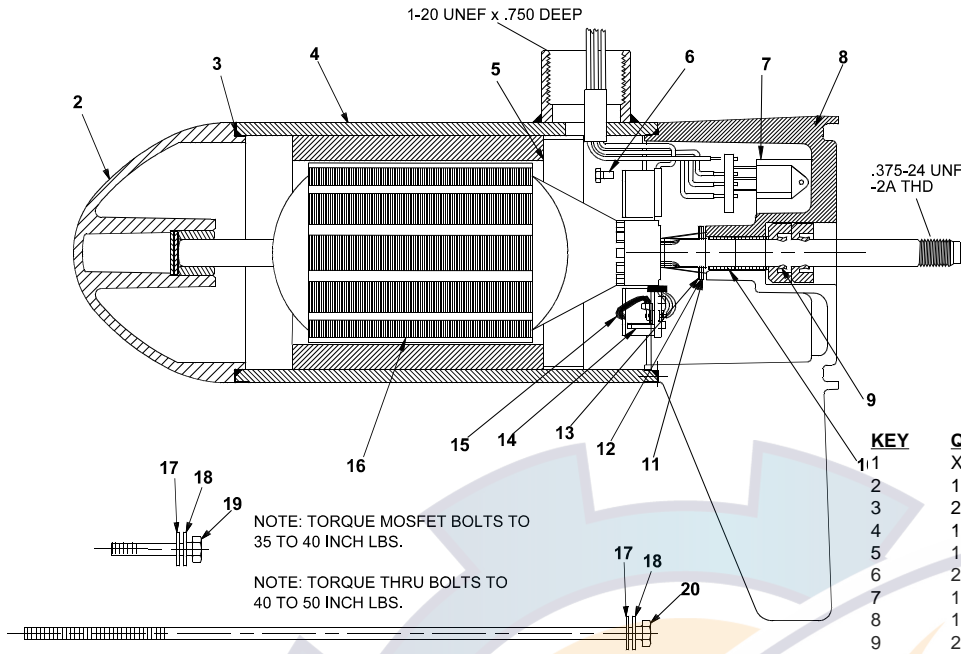

DIRECTION OF ROTATION IS COUNTER CLOCKWISE WHEN VIEWED FROM PROPELLER END WITH RED POSITIVE & BLACK NEGATIVE.

KEY	QTY	DESCRIPTION	PART NO.
1	X	MOTOR	GF397-01
2	1	NOSE CAP	JF3212-01
3	2	O RING SEAL	MR217-01
4	1	HOUSING ASY	GF3210-01
5	1	RETAINER	JF233-01
6	2	BRUSH CARD SCREW	MR228-01
7	1	DURA AMP MODULE	JF096-07
8	1	COMM CAP	JF3205-04
9	2	SHAFT SEAL	MR223-01
10	1	BEARING	MR206-01
11	1	NYLATRON WASHER	MR226-01
12	1	WASHER	MR227-01
13	1	E RING	MR219-02
14	2	BRUSH SPRINGS	MR214-02
15	1	BRUSH ASY LESS SPRING	GF3201-01
16	1	ARMATURE 3.5"	GF3207-01
17	4	STATIC SEAL	MR222-01
18	4	THRU BOLT WASHER	MR216-01
19	2	DURA AMP SCREW	MR229-04
20	2	THRU BOLT	MR218-04

**WIRING**

